

HOLES(4) ARE DESIGNED FOR M3X4mm SELF-TAPPING SCREWS USE. Four(4) M4X20mm PAN HEAD SCREWS.

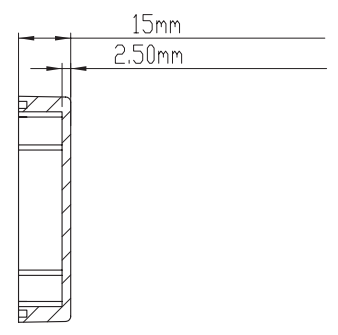

SECTION B-B
SCALE 2 : 3

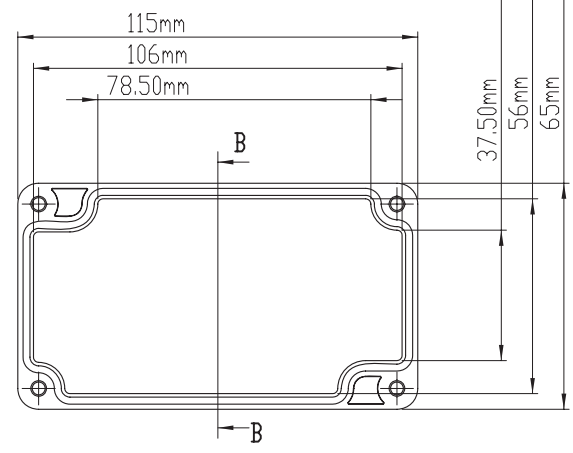
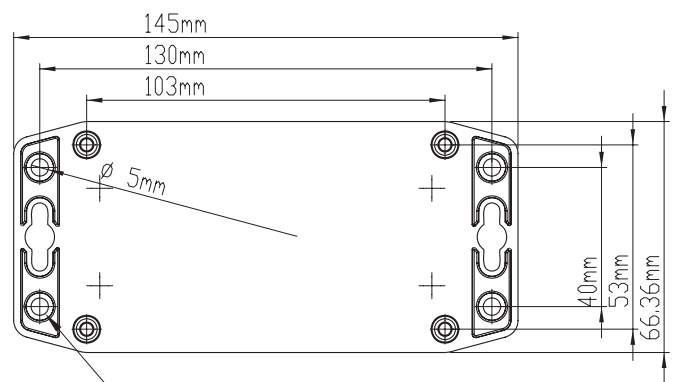

HOLES(4) ARE DESIGNED FOR M4 PAN HEAD MACHINE SCREWS USE.

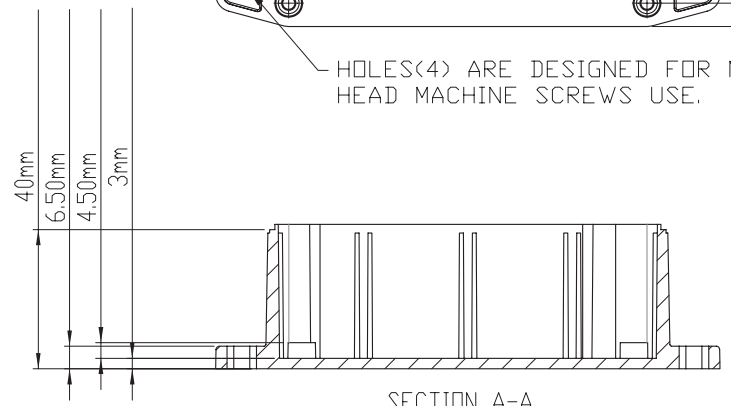
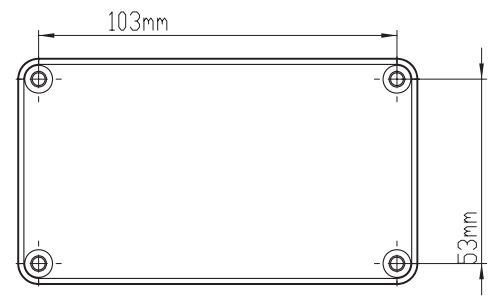

SECTION A-A
SCALE 2 : 3

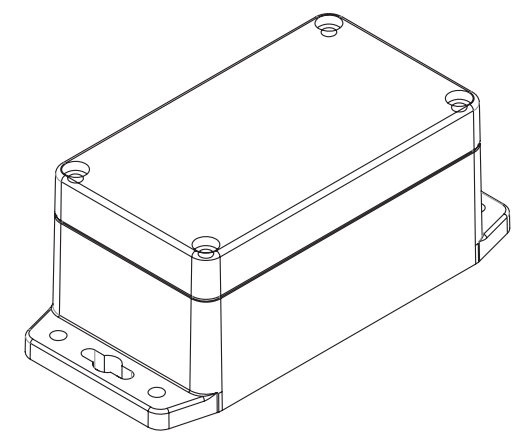
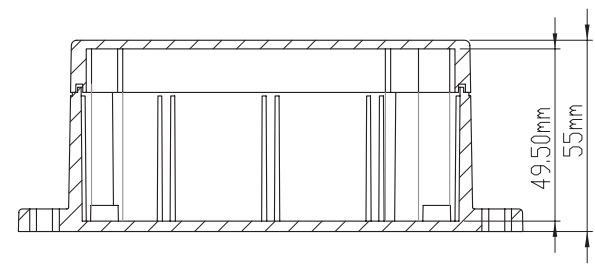

TOLERANCES: ± 0.30 mm (± 0.012 in)

宣又實業有限公司 GAINTA INDUSTRIES LTD.	繪圖	DRA'D BY	日期	DATE	材質	MATE.	圖名TITLE:	圖號DWG NO:	版次REVISID:
		JACKY	2010/11/8		PC ; ABS		G205MF ; G308MF		A